

## Fiber-optic Fanout Unit



### Features

- 1:4 fanout.
- Compact and cost-effective
- Low latency
- Digital signals can be transmitted across high voltage gaps or over long distances

### Applications

- Trigger signal distribution
- Logic level distribution in electrically noisy environments or across HV gaps

### Specifications

Fiber optic receiver	Number	One
	Wavelength	650 nm
Fiber-optic transmitter	Number	Four
	Wavelength	650 nm
Transmission delay	Typical	130 nsec rising, 140 nsec falling
	Maximum	150 nsec
Power input	+24V (+/- 2V) DC, 100 mA	
Case material	Stainless steel sheet, IP43	
Weight	0.16 kg (0.35 lb)	
Operating environment	10 to 35C, < 80% humidity, non-condensing, vibration < 0.2g all axes, 1 to 1000Hz	
Storage environment	0 to 50C, < 80% humidity, non-condensing, vibration < 2g all axes, 1 to 1000Hz	

### Connectors

Fiber optic input	One 1mm Avago ST bayonet.
Fiber optic outputs	Four 1mm Avago ST bayonet.
Power in	2.1mm threaded jack. Mates with Switchcraft S761K or equivalent.



Plan and side views

Dims mm

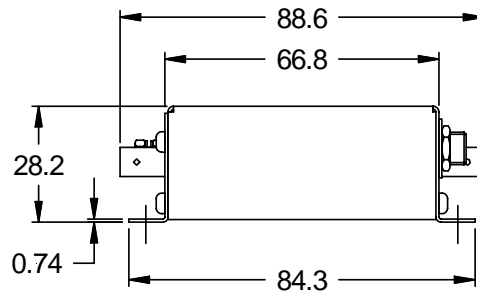
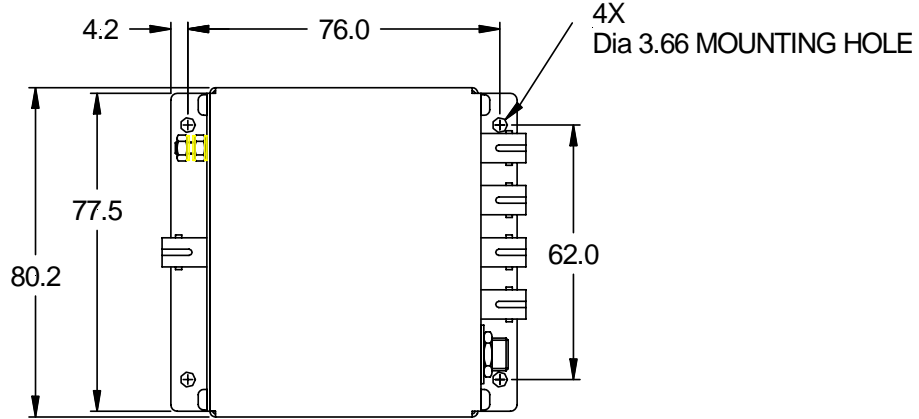

End panel views

FIBER-OPTIC RX  
M3 GROUND LUG

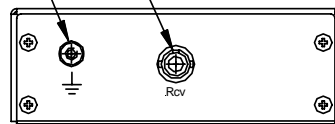

FIBER-OPTIC TX  
+24VDC  
POWER IN

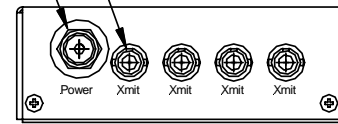

**Ordering information**

X14	X14 unit
-DIN	DIN rail adaptor

Pyramid Technical Consultants, Inc.,  
1050 Waltham Street Suite 200  
Lexington MA 02421 USA  
Tel: +1 781 402 1700 (USA),  
+44 1273 493590 (UK)

Email: support@ptcusa.com [www.ptcusa.com](http://www.ptcusa.com)

The information herein is believed accurate at time of publication, but no specific warranty is given regarding its use. All specifications are subject to change. Trademarks and copyright acknowledged.

X14\_DS\_090323

