

Four-channel Digital Electrometer for Quadrant BPM Readout



Features

- Four independent integrator channels with common gate
- Dynamic range <1 pA to 200 μ A
- Integrated digitization and filtering
- Fiber-optic, RS-232 and RS-485 interfaces.
- Integrated calibration test source
- Full control provided of integration modes
- External trigger capability
- Four independent analog monitor outputs, configurable to show various analog parameters such as current, position.
- Four independent frequency monitor outputs.
- Optional high voltage output

Applications

- Quadrant photodiode readout
- Low current and charge measurement
- Beam position monitors

Options

- Auxiliary HV output 0 to 1000V,
- Alternative feedback capacitor options

Specifications

Operating principle	Gated integrator (charge integrating amplifier)
Integration capacitor	Dual, software selectable
Input noise	< 100 fA rms + 1 fA rms per pF input load up to 100 pF (1 second integration, 100 pF capacitor)
Input offset	< 10 pA , 15 to 25 C. Offset can be removed by zero subtraction.
Stability	Output drift < 200 fA / C / hour



Specifications (continued)

External accuracy	Better than 0.5% of full scale in use, integration time 500 µsec to 1 sec, after calibration with built-in current source
Integration time	User selectable, 100 µsec to 65 sec.
External gate	TTL 10 kohm impedance
Trigger modes	Internal (autorun), external.
Digitization	16 bit bipolar
Averaging modes	Multiple conversions per integration; multiple integrations per reading to increase digital resolution up to 20 bits.
Auxiliary HV PSU	(Factory option) 0 to 1000V programmable (polarity and maximum voltage factory selectable), 1mA max. Noise and ripple < 0.1%
Power input	+24V (+/- 2V) DC, 350mA typ, 500mA max.
Controls	Two rotary switches for loop address and comms mode/ baud rate.
Displays	Status LEDs (power, device status, comms mode, data RX/TX). "HV on" LED.
Case material	Stainless steel sheet
Weight	1.64kg (3.6 lb).
Operating environment	10 to 35C (15 to 25 C recommended to reduce drift and offset) , < 70% humidity, non-condensing, vibration < 0.1g all axes (1 to 1000Hz) Vibration must be as low as possible to measure at the lower limit of the dynamic range.
Shipping and storage environment	-10 to 50C, < 80% humidity, non-condensing, vibration < 2g all axes, 1 to 1000Hz

Interfacing

Interfaces	RS-232 or RS-485, 8-bit ASCII. Selectable baud rate up to 115 kbos. The electrical interface can be set to be RS-232 levels, or full-duplex differential RS-485.
	Fiber-optic loop, 10 Mbit/sec serial, 9-bit asynchronous binary. Ethernet connection to host through A300 or A500 loop controllers.
Host computer	ASCII communications based on SCPI. Diagnostic host program supplied for Microsoft® .net framework. Binary DLLs available for Microsoft® .net, National Instruments™ Lab-view™, Microsoft® C++.and Linux.



Monitor outputs

Number	Four, independent analog voltage Four, independent frequency
Signal type	Analog voltage +/- 10V into 10 kohm. Frequency 0 to 1 MHz 5V into 50 ohm.
Software-selectable output parameter options	Current, four outputs active (relative to full scale for integration time and capacitor in use) Independent position, outputs A and B active $X = (INA - IND) / (INA + IND)$ $Y = (INB - INC) / (INB + INC)$ Quadrant position, outputs A and B active $X = ((IN1A + INC) - (INB + IND)) / (INA + INB + INC + IND)$ $Y = ((IN1A + INB) - (INC + IND)) / (INA + INB + INC + IND)$

Connectors

Signal inputs	Four BNC female.												
Auxiliary HV out	SHV												
External gate in	BNC (isolated from case)												
Monitor outputs	Four Lemo coax size 00 for analog voltage Four Lemo coax size 00 for frequency												
RS-232 / RS485	Six pin mini-DIN ("PS/2") <table border="1" data-bbox="553 1184 1305 1325" style="margin-left: 40px;"> <tr> <td>1</td> <td>Tx / RS-485 Tx-</td> <td>4</td> <td>n/c</td> </tr> <tr> <td>2</td> <td>Rx / RS-485 Rx+</td> <td>5</td> <td>RS-485 Tx+</td> </tr> <tr> <td>3</td> <td>Gnd</td> <td>6</td> <td>RS-485 Rx-</td> </tr> </table>	1	Tx / RS-485 Tx-	4	n/c	2	Rx / RS-485 Rx+	5	RS-485 Tx+	3	Gnd	6	RS-485 Rx-
1	Tx / RS-485 Tx-	4	n/c										
2	Rx / RS-485 Rx+	5	RS-485 Tx+										
3	Gnd	6	RS-485 Rx-										
Fiber optics	TX & RX ST bayonet, suitable for 1mm plastic fiber or 200 μm HCS fiber.												
Power in	2.1mm threaded jack. Mates with Switchcraft S761K or equivalent.												
Ground	M3 threaded stud												

Ordering information

I404	I404 four channel electrometer with user manuals, software drivers, calibration data.
-XP1000/500/200 (-XN)	Add auxiliary HV supply positive 1000 V / 500 V / 200 V (negative)
-C1/x/y	Specify feedback capacitors x pF, y pF. (Default is 100pF, 3300pF.)



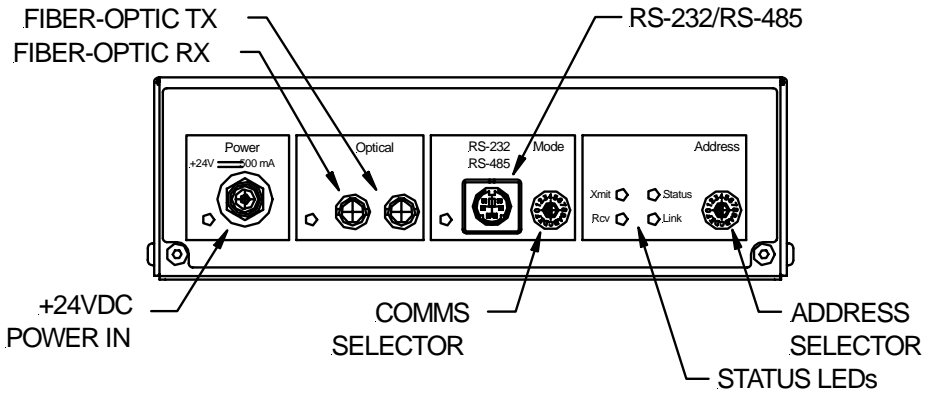
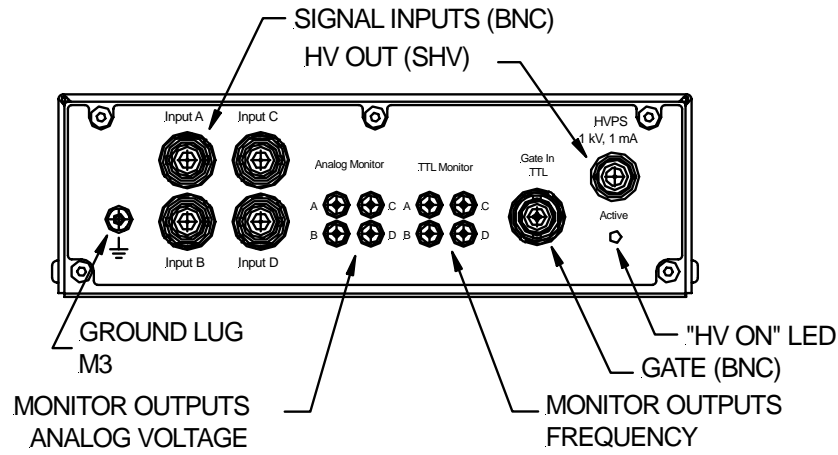

Pyramid Technical Consultants, Inc.,
 1050 Waltham, Street Suite 200
 Lexington, MA 02421 USA
 Tel: +1 781 402 1700 (USA),
 +44 1273 493590 (UK)

Email: support@ptcusa.com

www.ptcusa.com

The information herein is believed accurate at time of publication, but no specific warranty is given regarding its use. All specifications are subject to change.

All trademarks acknowledged

I404_DS_100505



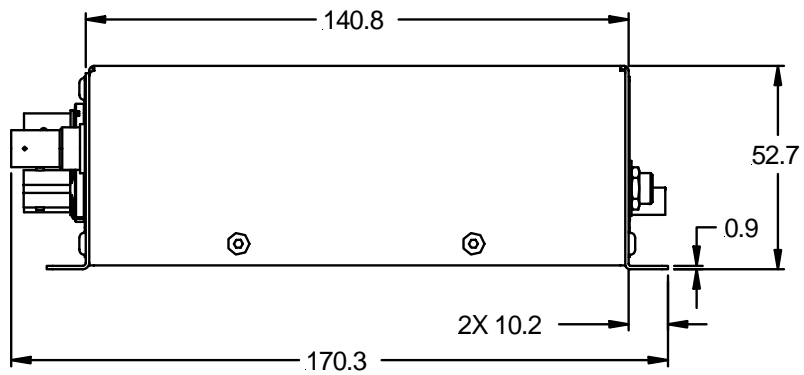
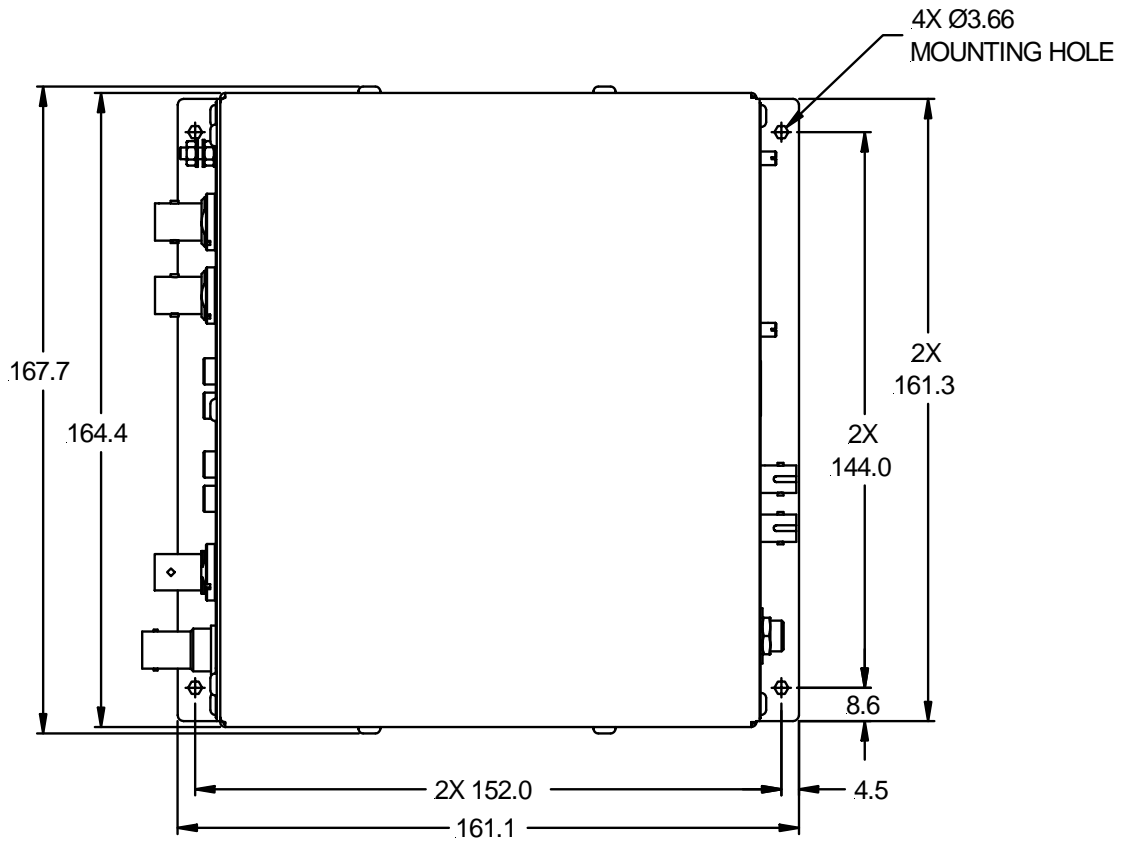

Dims mm

