

Digital Device Interface



Features

- Compact and cost-effective package.
- Permits simple interfacing of existing devices to a fast fiber-optic communication loop.
- Can be mounted on or close to the device being controlled
- Up to sixteen devices can be connected on a single fiber-optic loop
- 8 fast TTL inputs, 8 fast TTL outputs.
- Encoder read facility

Applications

- Read and control digital devices.
- Control of devices across high voltage barriers.
- Fully automated systems operating in electrically noisy environments.
- Addition of high-performance remote control to existing systems.
- Read quadrature encoder inputs from motion systems.
- Read and send out arbitrary pulse trains.
- Eight-bit parallel I/O
- Serial I/O

Specifications

Digital output	Number of independent outputs Voltage level Maximum current drive capability Output impedance Minimum output pulse length	Eight TTL 24 mA, limited by 1 kohm series resistor 100 ohm 15 nsec
Digital input	Number of independent inputs Voltage level Configuration Input impedance Maximum input pulse rate	Eight TTL Active low, internal 10 kohm pullup to +5 V 10 kohm > 10 MHz



Specifications (continued)

Encoder inputs	Number of inputs, A & B	Two, Enc 1 uses DigIn 1,2 with index on DigIn 3 Enc 2 uses DigIn 5,6 with index on DigIn 7
	Maximum pulse rate	10 MHz
	Counters	Two, independent, bidirectional

Power input	+24V (+/- 2V) DC, 250mA maximum
Controls	16 position rotary switch for address selection
Displays	Status LEDs (power, processor status, comms status)
Case material	Stainless steel sheet.
Weight	0.24kg (0.55 lb)
Operating environment	10 to 35C, < 80% humidity, non-condensing, vibration < 2g all axes, 1 to 1000Hz
Storage environment	0 to 50C, < 80% humidity, non-condensing, vibration < 2g all axes, 1 to 1000Hz

Interfacing and control

Interfaces	Fiber-optic loop, 9600 to 10 Mbit/sec serial, 8 or 9 bit asynchronous binary.
Data rate	Typical read/write rate \geq 1 kHz, depending upon loop configuration. Rate to A500 host memory (special applications) \geq 10kHz.
	Fibre-optic loop to host system interfacing available using loop controllers: A100 (RS-232), A200 (USB), A300 (Ethernet), A500 (Real-time controller)
Host computer	Diagnostic host program provided for PC. Embedded software DLLs available for Microsoft® .NET, Labview and C++.



Connectors

Fiber optics	Two 1mm ST bayonet to suit 1mm platic fiber or 200 um HCS fiber			
Power in	2.1mm threaded jack. Mates with Switchcraft S761K or equivalent.			
Signal	25 way DSub female			
	1	PSU 0V in	14	+24V DC in
	2	Shield (B10 case)	15	Digital ground
	3	Digital out 8	16	Digital out 7
	4	Digital out 6	17	Digital out 5
	5	Digital out 4	18	Digital out 3
	6	Digital out 2	19	Digital out 1
	7	Digital ground	20	+5V digital out
	8	Digital ground	21	Digital ground
	9	Digital in 8	22	Digital In 7
	10	Digital in 6	23	Digital In 5
	11	Digital in 4	24	Digital In 3
	12	Digital In 2	25	Digital In 1
	13	Digital ground		

The device may be powered through pins 14 and 1 as an alternative to the power in jack.

Ordering information

- B10A B10 device with eight TTL digital inputs and eight TTL digital outputs. Including PTCDiagnostic host software

- B10B B10 device with four opto-coupled digital inputs and four opto-coupled digital outputs. Including PTCDiagnostic host software

See separate data sheet.

- B10C B10 device with eight TTL digital inputs and four relay outputs. Including PTCDiagnostic host software

See separate data sheet.



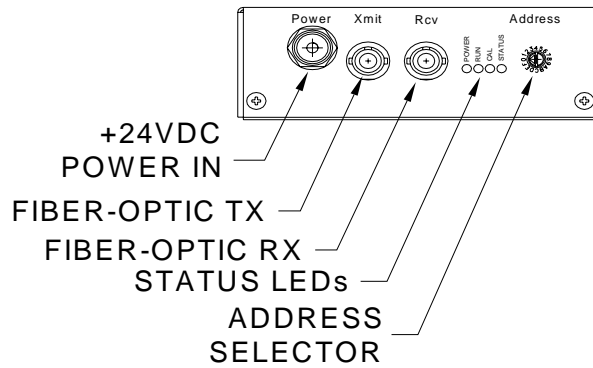
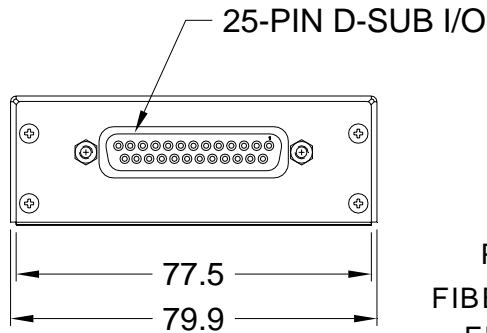
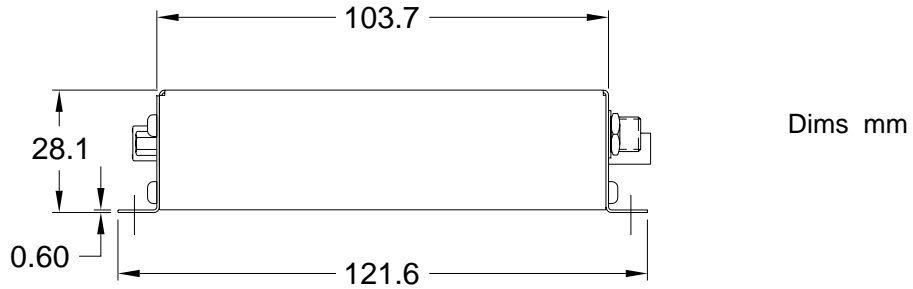
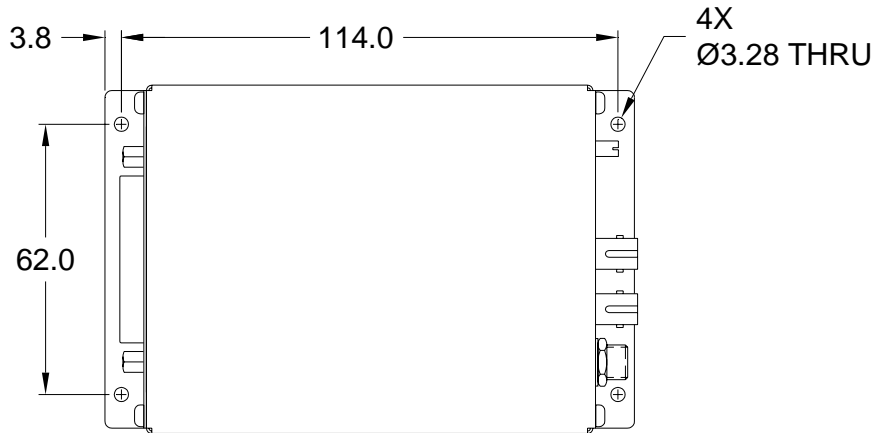

Pyramid Technical Consultants, Inc.,
 1050 Waltham Street Suite 200
 Lexington MA 02421 USA
 Tel: +1 781 402 1700 (USA),
 +44 1273 493590 (UK)
 Email: support@ptcusa.com

www.ptcusa.com

The information herein is believed accurate at time of publication, but no specific warranty is given regarding its use. All specifications are subject to change. Trademarks and copyright acknowledged.

B10A_DS_080724



Recommended Connection Arrangements

Digital input : TTL input

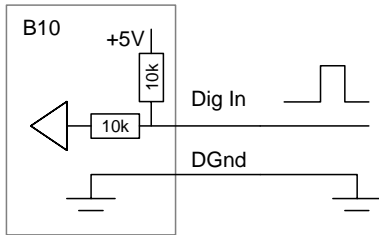

Digital input : volts-free contact

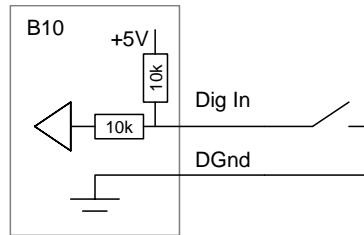

Digital input : optoisolator

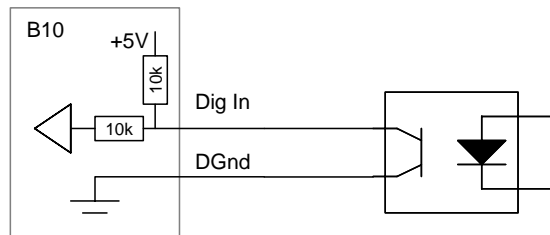

Digital output : TTL load

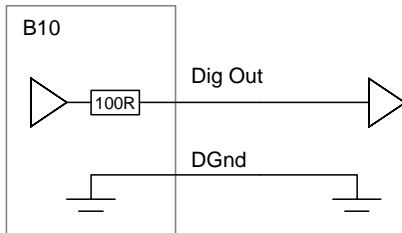

Digital output : optoisolator load

